

LUX DD 235-100/8

HIGH SPEED DRIFT-DWELL MOTION DOYPACK MACHINE

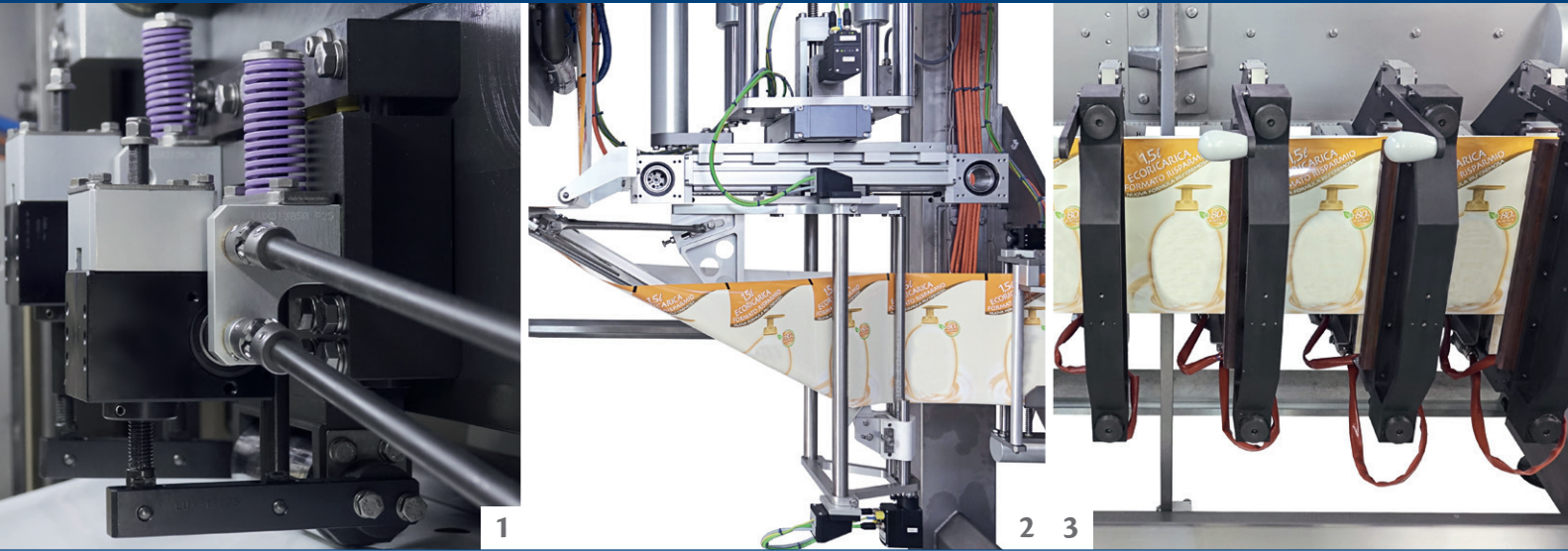

LUX DD 235-100/8



The Ilapak machine is a revolutionary new range of innovative high speed pouch machinery with a unique duel motion system composed of an intermitted module for pouch forming and fitments application, combined with a continuous unit for product filling. The Ilapak solution has been designed to form flat film roll stock into high quality Doypack bag, with fully integrated filling solutions for liquid products. Given its versatility, the LUX machine is suitable for a wide number of bag dimensions and filling volumes, as well as the possibility to equip the Doy pouches with corner spout application, shaped round corners and handle punch.

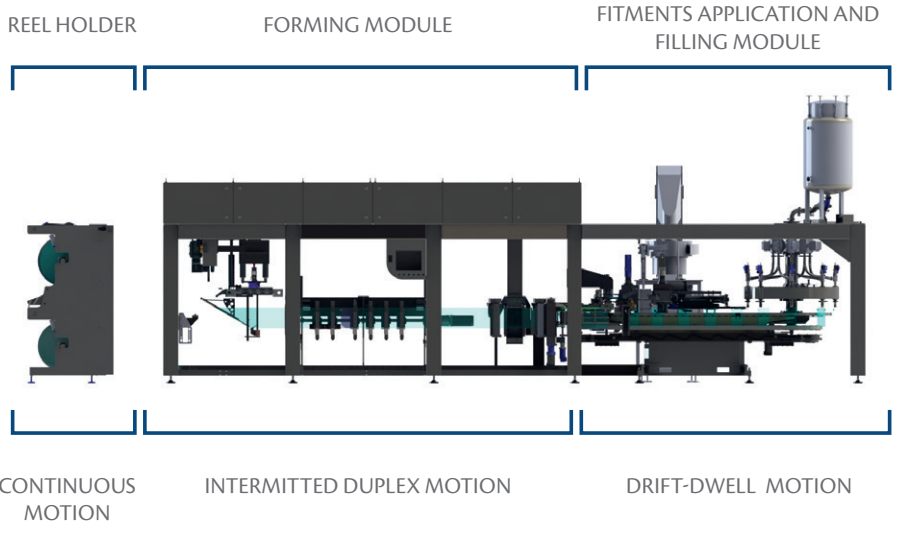

EXAMPLES OF TARGET INDUSTRIES



Home & Personal Care



Preserves and condiments



Corner spout/handle



Corner spout



Handle



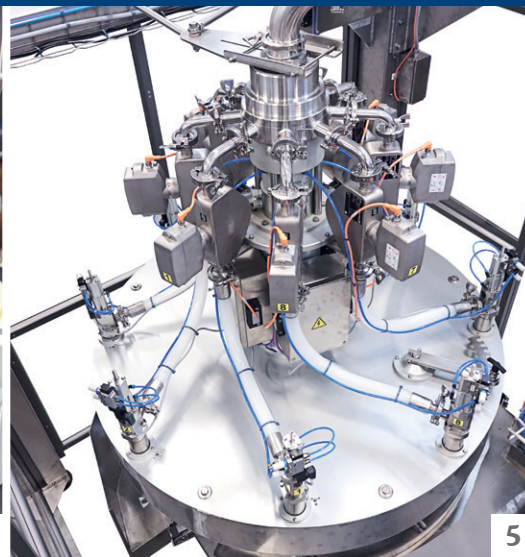

1 BOTTOM PUNCHING UNIT

2 MOVING TRIANGLE

3 SEALING UNITS

4 CORNER SPOUT APPLICATION/SEALING

5 CONTINUOUS DOSING UNIT

6 OUTFEED CAROUSEL

BENEFITS

- Rotary servo punch
- No tool changeover and programmable.
- Servo controlled forming triangle
- Dual motion to control the film tension and to actively keep the top fins aligned.
- Dedicated eyemark reading sensors for the forming and cutting units
- Increased precision of pouch positioning during the sealing operation and reduced tolerance of single pouch cutting intersection, by elimination of eyemark reading errors accumulation.
- Continuous and rotary motion cutting system
- Increased speed of the unit, format registration for pouch width controlled by the PLC and elimination of multiple units requirement.
- Drift-dwell motion system
- Combined benefits of the intermittent motion for the pouch fitments application and the advantages of the continuous motion for an increased dosing time
- Corner spout pre-heating system
- Special system to pre-heat the sealing section of the corner spout in order to minimize the sealing temperature gap with the pouch film and to reduce the overall sealing time
- Pouch extraction carousel at machine outfeed
- Possibility to discriminate between good and rejected pouches, keeping control on the pitch between the released bags on the outfeed belt, allowing for an orderly disposition to a potential inline check weigher. Integrated top cooling optional

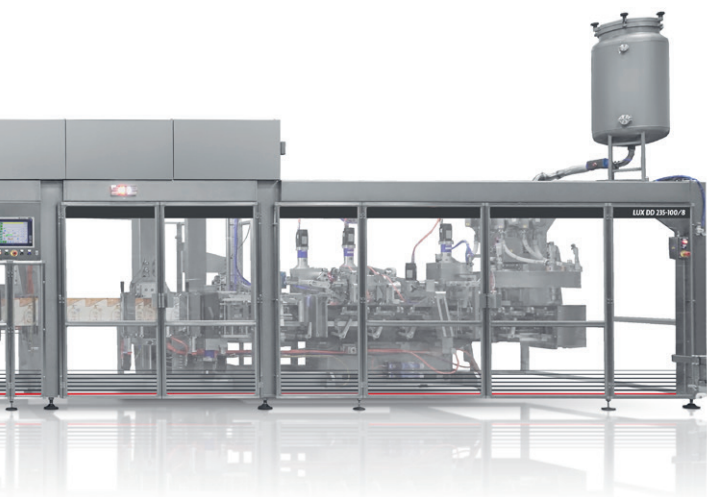

*All pouch versions available with or without round corners

*Additional solutions for solid products applications available

TECHNICAL DATA

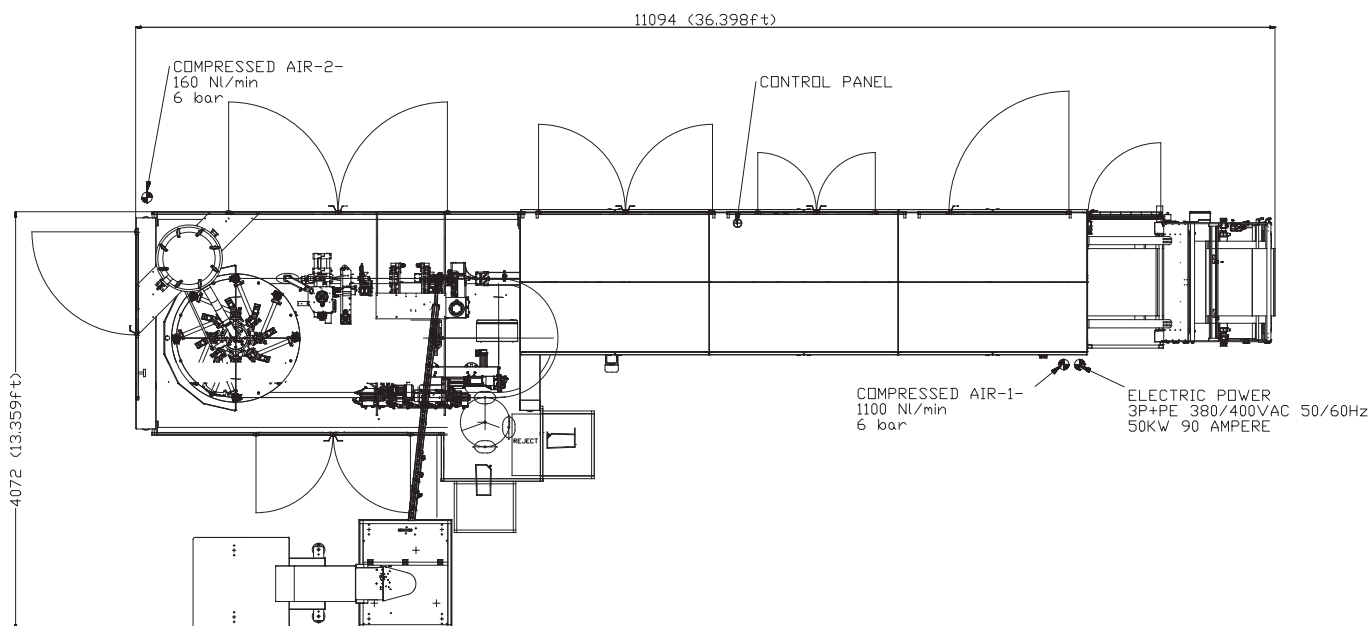

Noise level	within 80db
Maximum reel dimension	eØ 600mm - 23.622"
Reel core	iØ 76/152mm - 2.992" / 5.984"
Electrical consumption	400/480VAC - 50/60Hz
Pressure and air consumption	6 bar - 750NL/min + 600NL/min
Minimum/Maximum pouch width	120/235 mm - 4.724" / 9.251"
Minimum/Maximum pouch height	190/330 mm - 7.480" / 12.992"
Minimum/Maximum pouch gusset height	15/60 mm - 0.59" / 2.362"
Target output - up to 500 ml.	100 ppm
Target output - up to 1,5 lt.	70 ppm
Filling stations	8



ILAPAK INTERNATIONAL S.A.
P.O. Box 756 CH-6916 Grancia - Switzerland
Phone +41 (0) 91 960 5900 - Fax +41 (0) 91 960 5992
marketing@ilapak.com • ima.it

