

LUX DC235-150/8

HIGH SPEED CONTINUOUS MOTION DOYPACK MACHINE

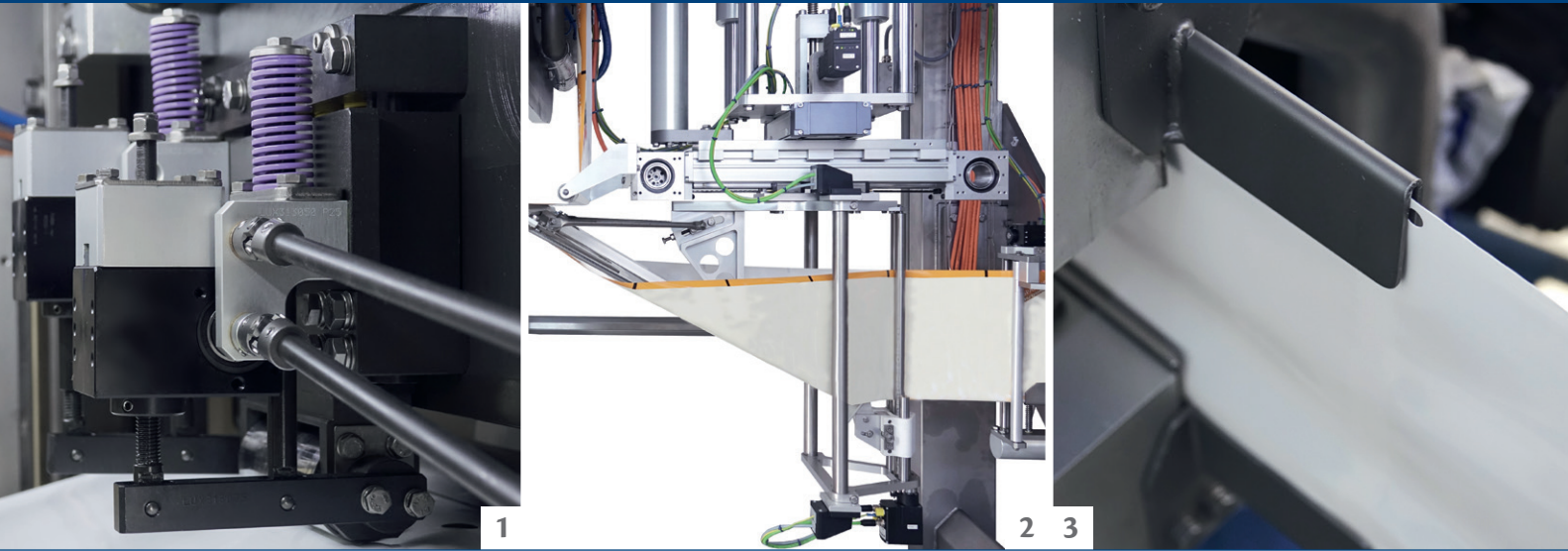

LUX DC235-150/8



The Ilapak LUX machine is a revolutionary new range of innovative high speed pouch machinery with an unique dual motion system composed of an intermittent module for pouch forming and a continuous module for product filling. This Ilapak solution has been designed to form flat film roll stock into high quality Doypack bags with fully integrated filling solutions for solid and granular products. Given its versatility, the LUX machine is suitable for a wide number of bag dimensions and filling volumes, as well as the possibility to equip the Doy pouches with re-closable zipper, shaped round corners, easy open tear notch and hole punch.

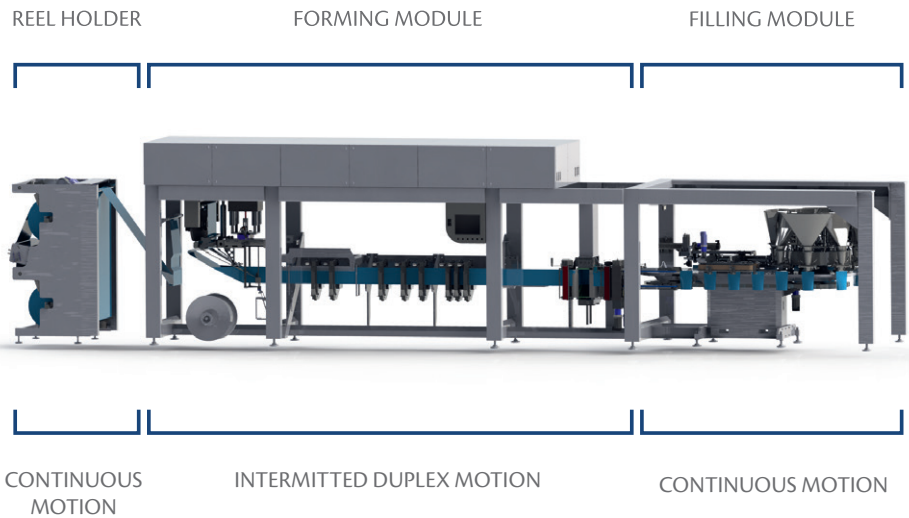

EXAMPLES OF TARGET INDUSTRIES



Pet food



Chocolate & Confectionery



Snacks



Cereals



3/4SS



Doy with hang hole



Doy with round corners



Doy with tear notch and zipper

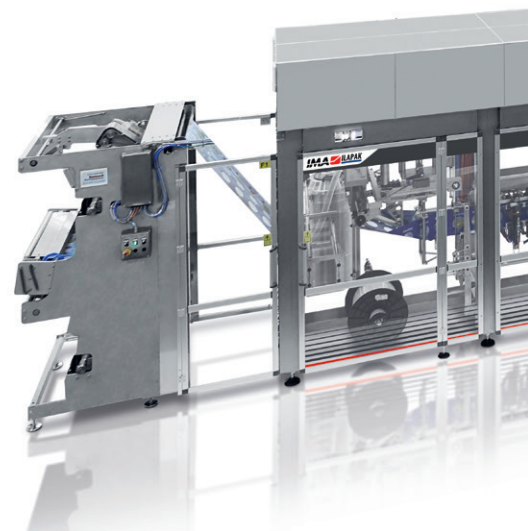

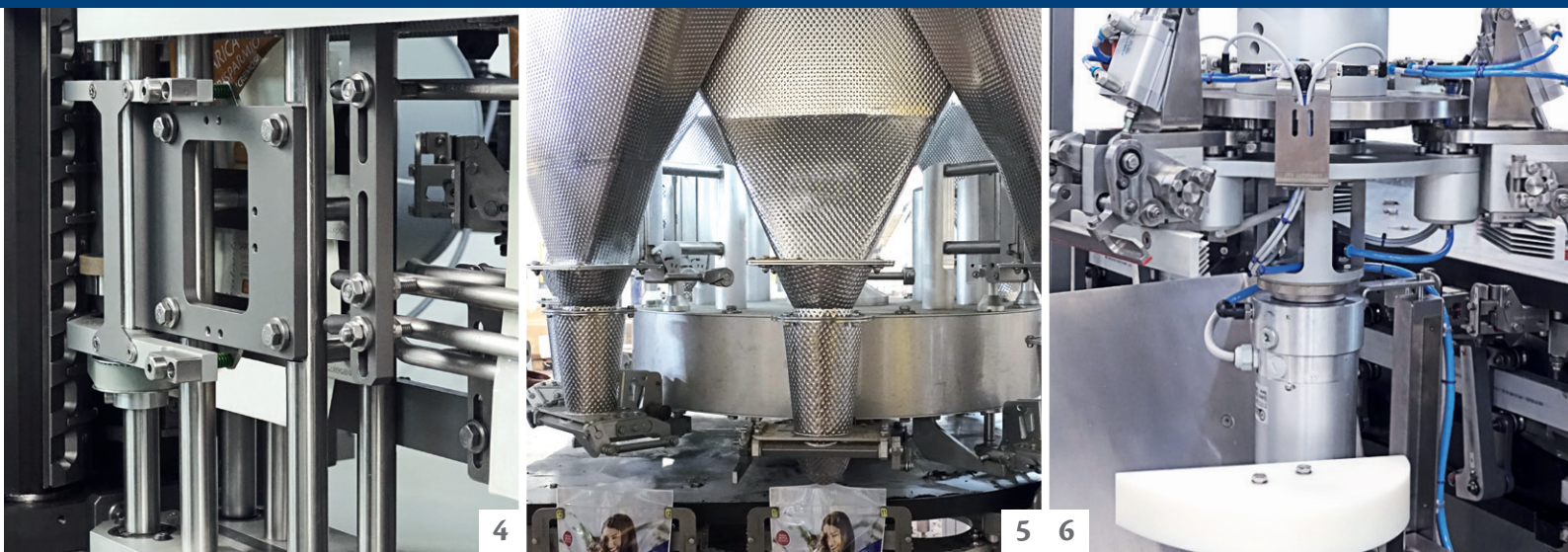

1 BOTTOM PUNCHING UNIT

2 MOVING TRIANGLE

3 POUCH SHAPING

4 CONTINUOUS ROTARY KNIFE AND PHASING BELTS

5 CONTINUOUS DOSING UNIT

6 OUTFEED CAROUSEL

BENEFITS

- Rotary servo punch
- No tool changeover and programmable
- Servo controlled forming triangle
- Dual motion to control the film tension and to actively keep the top fins aligned
- Dedicated eyemark reading sensors for the forming and cutting units
- Increased precision of pouch positioning during the sealing operation and reduced tolerance of single pouch cutting intersection, by elimination of eyemark reading errors accumulation
- Continuous and rotary motion cutting system
- Increased speed of the unit, format registration for pouch width controlled by the PLC and elimination of multiple units requirement
- Continuous motion dosing unit
- Increased dosing time for higher production speeds, high volumes or difficult product dosages
- Pouch extraction carousel at machine outfeed
- Possibility to discriminate between good and rejected pouches, keeping control on the pitch between the released bags on the outfeed belt, allowing for an orderly disposition to a potential inline check weigher. Integrated top cooling optional



*All pouch versions available with and without zipper

*Additional solutions for liquid products applications available

TECHNICAL DATA

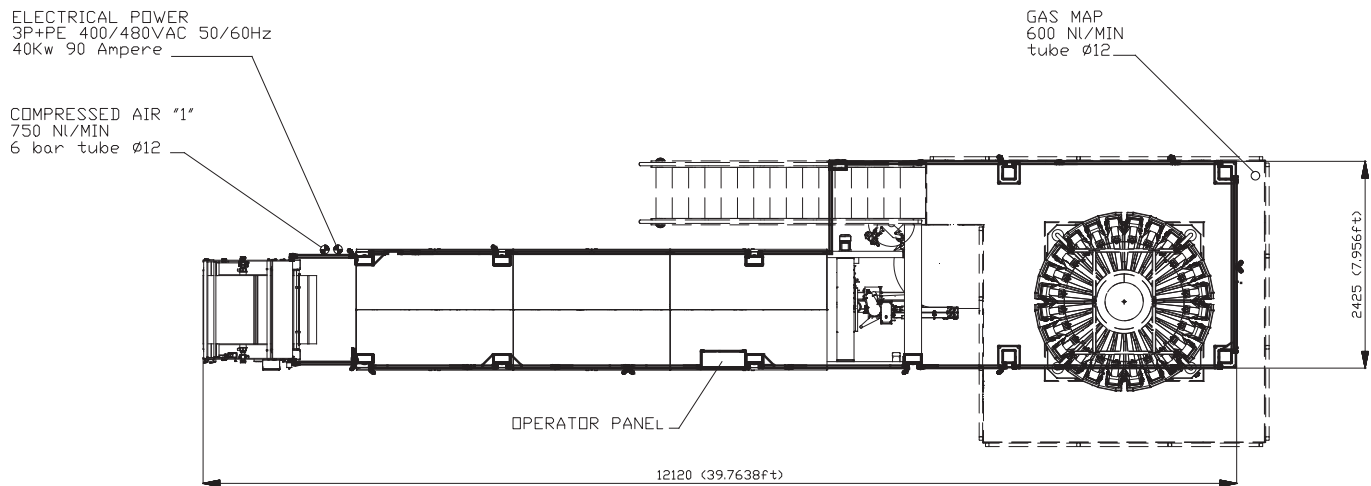

Noise level	within 80db
Maximum reel dimension	eØ 600mm - 23.622"
Reel core	iØ 76/152mm - 2.992" / 5.984"
Electrical consumption	400/480VAC - 50/60Hz
Pressure and air consumption	6 bar - 750NL/min + 600NL/min
Minimum/Maximum pouch width	120/235 mm - 4.724" / 9.251"
Minimum/Maximum pouch height	190/330 mm - 7.480" / 12.992"
Minimum/Maximum pouch gusset height	15/60 mm - 0.59" / 2.362"
Target output - up to 400 grs.	150 ppm
Target output - up to 800 grs.	110 ppm
Filling stations	8

May 2020 - LUXDC2351508EN

Ilapak reserves the right to make any changes to the described machine characteristics.



ILAPAK INTERNATIONAL S.A.
P.O. Box 756 CH-6916 Grancia - Switzerland
Phone +41 (0) 91 960 5900 - Fax +41 (0) 91 960 5992
marketing@ilapak.com • ima.it

